



A THERMADYNE Company



MORE ARC ACCESSORIES

(C) GOUGING ELECTRODES

USEFUL INFORMATION.

# Angle-Arc® Manual Gouging Torches

Scan for Current Price Page



Only Arcair® – the inventor of the original air carbon arc process and the industry leader for 50 years – could bring you the superb marriage of proven technology and improved design. Only Angle-Arc Torches work efficiently with the natural angles and movements of the arm and wrist. This major advance in gouging and cutting equipment delivers rugged reliability. The addition of superb support and complete technical backup makes Arcair the number one name in air carbon arc manual torches.

Arcair Angle-Arc Torches are highly efficient metal removal tools for fabrication jobs in steel fabrication plants, shipyards, railroads, farms . . . anywhere people want to save time and money. They speed up weld removal, back gouging, edge preparation, defect repair and many other metal removal jobs. They are ideal for almost all metals – with little or no deformation – because the heat input is so low.

Now a complete family of Angle-Arc Torches to meet your everyday needs. Just pick the best torch to fit your gouging applications.

## New & Improved Air Flow and Four Barrel Air Nozzle Gives Optimum Metal Removal

Check out these exciting features of the new Extreme™ Gouging Torch From Arcair®:

**Improved Torch Air Flow:** More efficient use of air supply. Improved metal removal.

**New Four Barrel Air Nozzle:** Optimizes airflow to the arc. Efficiently cleans slag from groove edge.

**Optimized Air Flow to Control Noise:** Allows usage in areas where noise cannot exceed 115 decibels. Able to use torch at lower air pressure and flow to obtain acceptable grooves.

**Air Assist Positive Air Shut-Off:** Minimizes air supply unit cycling on and off. Allows torch usage when air supply is marginal.

**Improved Cable Electrical Conduction:** Improves cable service life. Decreases heat build up in cable and torch.

**Superior Outer Cable Cover:** Durable cover for improved cable life in a harsh environment. Resists breakdown due to exposure to heat produced by gouging.

## FEATURES & BENEFITS

**Natural 15° Torch Angle:** Greater operator comfort

**360° Swivel Cable:** Less cable twist. Less strain on operator

**Positive Grip Handle:** Greater operator feel and ease in positioning the torch

**Reduced Weight:** Optimum cable and torch weight to minimize fatigue

**High Quality Cable Hose:** Best quality cable hose offers high heat and abrasion resistance

**Rugged Construction:** Overall rugged construction for the harsh environment

## Angle-Arc® Manual Gouging Torch Parts

K2000 and K4000 Torch (K4000 Shown)

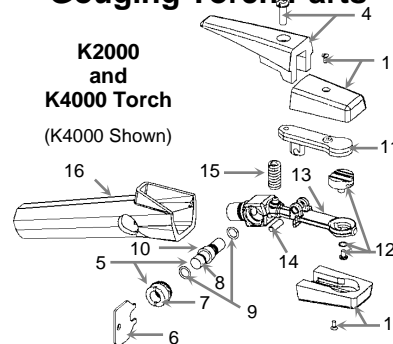

## Torch Assembly Replacement Parts

Item	Description	Part (Order) No.	Price	FOR K2000	FOR K4000
1	Insulators & Screws	94-433-193	\$18.38 pk	X	-
		94-433-183	\$21.20 pk	-	X
		97-142-009	\$1.50 ea	X	X
2	Upper Insulator	See #1	N/A	X	X
3	Lower Insulator	See #1	N/A	X	X
4	Lever & Screw	94-476-080	\$25.00 ea	X	-
		94-476-066	\$36.92 ea	-	X
5	Valve Bonnet	94-104-016	\$72.68 ea	X	X
6	Bonnet Wrench	94-960-001	\$6.95 ea	X	X
7	Bonnet Only	94-104-012	\$31.66 ea	X	X
8	Spool & O-Rings	94-801-011	\$36.68 ea	X	X
9	O-Ring (2 Reqd.)	94-710-036	\$14.25 ea	X	X
10	Spool Only	94-801-010	\$32.86 ea	X	X
11	Upper Arm	94-048-119	\$60.82 ea	X	-
		94-048-088	\$67.78 ea	-	X
		94-378-364	\$47.34 ea	X	-
12	Head & Screw	94-378-368	\$56.82 ea	-	X
		97-192-125	\$4.78 ea	X	X
13	Torch Body	94-103-233	\$126.00 ea	X	-
		94-103-206	\$160.00 ea	-	X
14	Hinge Pin	94-632-100	\$6.95 ea	X	-
		94-632-094	\$6.99 ea	-	X
15	Spring	94-800-191	\$24.16 ea	X	-
		94-800-077	\$14.92 ea	-	X
		94-370-179	\$58.68 ea	X	-
16	Handle	94-370-163	\$60.98 ea	-	X



Light Duty

### K2000

Accepts:

Pointed Carbons:  
1/8" (3mm) to 1/4" (6mm)

Flat Carbons:  
3/8" (10mm)

Maximum 450 Amps

Compressed air:

Pressure: 40 psi (2.8kg/cm<sup>2</sup>)  
Flow Rate: 8 cfm (0.23m<sup>3</sup>/min)

Torch & Cable Weight: 3.6 lbs. (1.6kg)

K2000 Torch (Only)

Part (Order) No. **01-046-001**

Price: **\$185.00 ea**

K2000 Torch W/ 7ft. Cable  
Part (Order) No. **61-046-006**

Price: **\$322.90 ea**

K2000 Torch W/ 10ft. Cable  
Part (Order) No. **61-046-007**

Price: **\$382.60 ea**



Heavy Duty

### K4000

Accepts:

Pointed Carbons:  
5/32" (4mm) to 1/2" (13mm)

Flat Carbons:  
3/8" (10mm) & 5/8" (16mm)

Maximum 1000 Amps

Compressed air:

Pressure: 80 psi (5.6kg/cm<sup>2</sup>)  
Flow Rate: 28 cfm (0.79m<sup>3</sup>/min)

Torch & Cable Weight: 5.4 lbs. (2.4kg)

K4000 Torch (Only)

Part (Order) No. **01-082-002**

Price: **\$329.00 ea**

K4000 Torch W/ 7ft. Cable  
Part (Order) No. **61-082-008**

Price: **\$545.00 ea**

K4000 Torch W/ 10ft. Cable  
Part (Order) No. **61-082-009**

Price: **\$569.70 ea**

Replacement Swivel Cable	For K2000		For K4000	
	Part No.	Price ea	Part No.	Price ea
7ft	70-088-107	\$184.27	70-084-207	\$210.17
10ft	70-088-110	\$230.75	70-084-210	\$297.92

## POWER & AIR HOOKUP ADAPTER (No Cable)

PART # **94-463-045**

**\$93.50 EA**

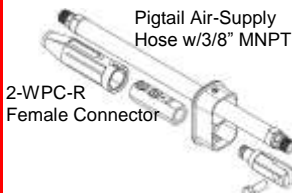

2-WPC-R Female Connector

## The Air Carbon Arc Process and the ARCAIR® Torch ...

Myron D. Stepath originated the air carbon arc gouging process during World War II while working as a welding engineer with the U.S. Navy... conceiving the idea of combining the carbon arc to melt metal, and compressed air to blast the molten puddle out of the gouge or groove. He did this to solve the extremely difficult and critical problem of removing defective stainless steel welds in armor plate on U.S. warships, since conventional methods such as chipping and grinding had proved unfeasible due to time and cost factors. It required two welders to accomplish the work; one to apply the arc and one to direct the air nozzle. After the war, Stepath experimented with methods to combine the arc and air into a single, usable, efficient, hand-held tool. He thus produced the world's first air carbon arc torch and, with several associates, founded The Arcair Company in 1949

### Recommended Minimum Air Requirements

	Air Pressure <sup>1</sup>		Air Consumption		Compressor Rating				ASME Receiver Size	
	psi	Kpa	cfm	L/min	Light Use	Heavy Use	hp	kW	gal	lit.
Type of Torch										
Light Duty <sup>2</sup>	40	280	8	227	.5	0.4	1.5	1.1	60	227
General Duty <sup>2</sup>	80	550	25	708	5	3.7	7.5	5.6	80	303

- Pressure while torch is in operation.
- Accommodates flat electrodes

AIR INLET 3/8" PIPE FEMALE  
STUD HOLE 17/32"

